

A.P.P Bulkheads in stow position
2 pcs bulkheads

F.P.P

Cement holes

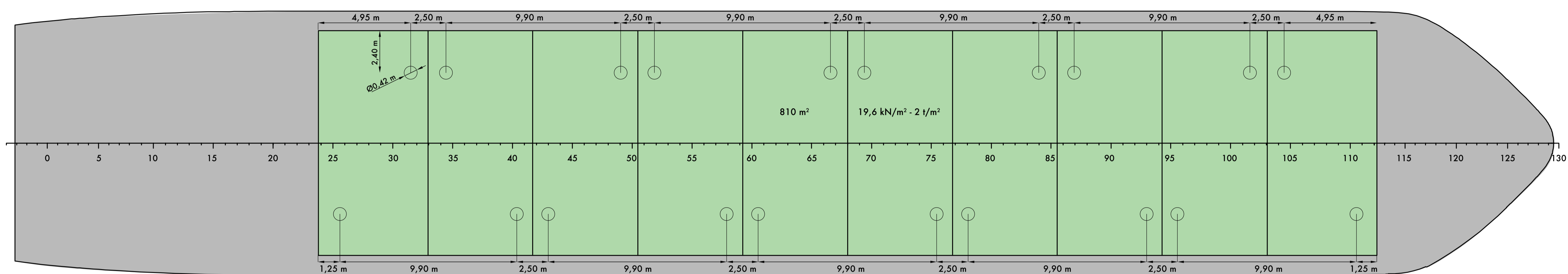

Tank top

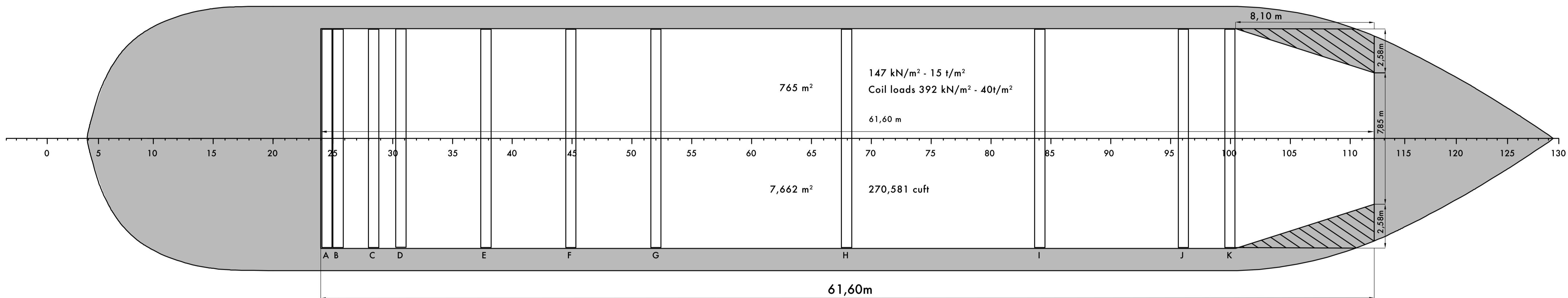

GENERAL PARTICULARS

Length over all	89,98 m
Length between P.P.	88,06 m
Breadth moulded	15,45 m
Depth to weather deck	8,80 m
Depth to maindeck moulded	7,40 m
Draught summer	6,20 m
Deadweight summer	5200 t
Gross Tonnage	3.961 GT
Net Tonnage	1.923 NT
Hold capacity, incl. BH	270.581 cuft
	7.662 m³
Main engine MCR	2.100 kW
Bulk heads	0,60 m
Coil loads	392 kN/m² - 40t/m²
Pay load on hatch cover:	19,6 kN/m² - 2t/m²
Pay load on hatch cover & TD:	24,5 kN/m² - 2,5t/m²

Ballast water tank full: Water line to hatch coaming: 7,05 m
Ballast water tank at minimum: Waterline to hatch coaming: 8,72 m

Summer draft: 6,20m
Winter draft: 6,064m
Winter NA draft: 6,014m

Winter 1. November - 31. March
Winter North Atlantic. 15. October - 16. April

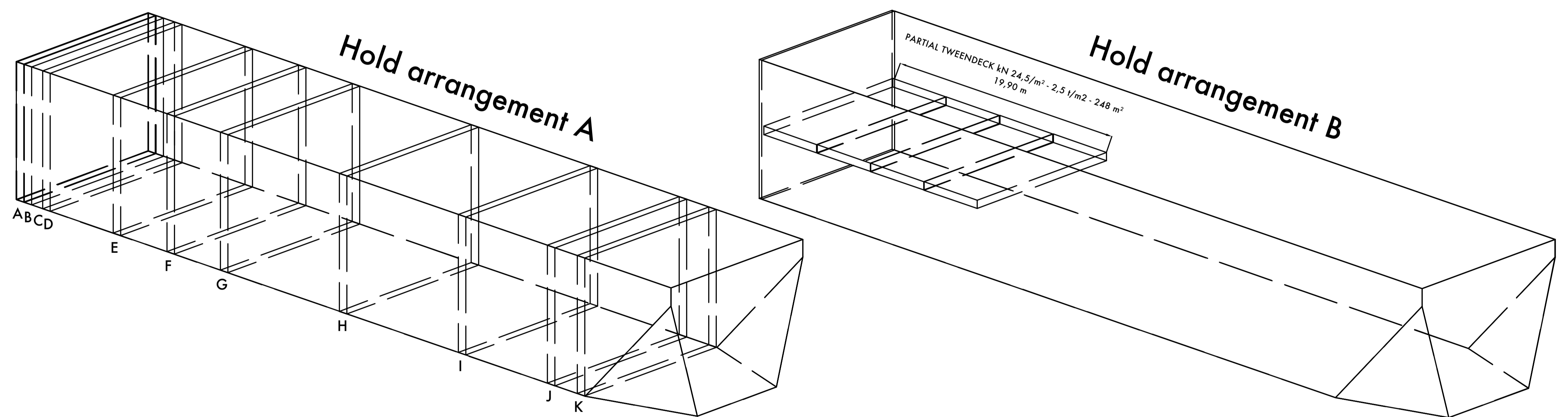

Draft at 100 ton oil and 30 ton water
+/- Depend on other liquid and weight

Draft at 100 ton oil and 30 ton water			
Draft (m)	DWTC (t) density 1,00	DWTC (t) density 1,025	t/cm
2,80 m	751	822	11,37
3,00 m	973	1050	11,45
3,20 m	1197	1280	11,54
3,40 m	1423	1512	11,64
3,60 m	1652	1746	11,76
3,80 m	1882	1982	11,89
4,00 m	2115	2221	12,00
4,20 m	2351	2462	12,12
4,40 m	2588	2705	12,20
4,60 m	2827	2950	12,30
4,80 m	3068	3197	12,39
5,00 m	3310	3446	12,49
5,20 m	3555	3697	12,59
5,40 m	3801	3949	12,69
5,60 m	4050	4204	12,78
5,80 m	4300	4461	12,88
6,00 m	4553	4719	12,99
6,02 m	4578	4745	13,00
6,07 m	4642	4810	13,02
6,20 m	4807	4980	13,08
6,36 m	4980		13,13

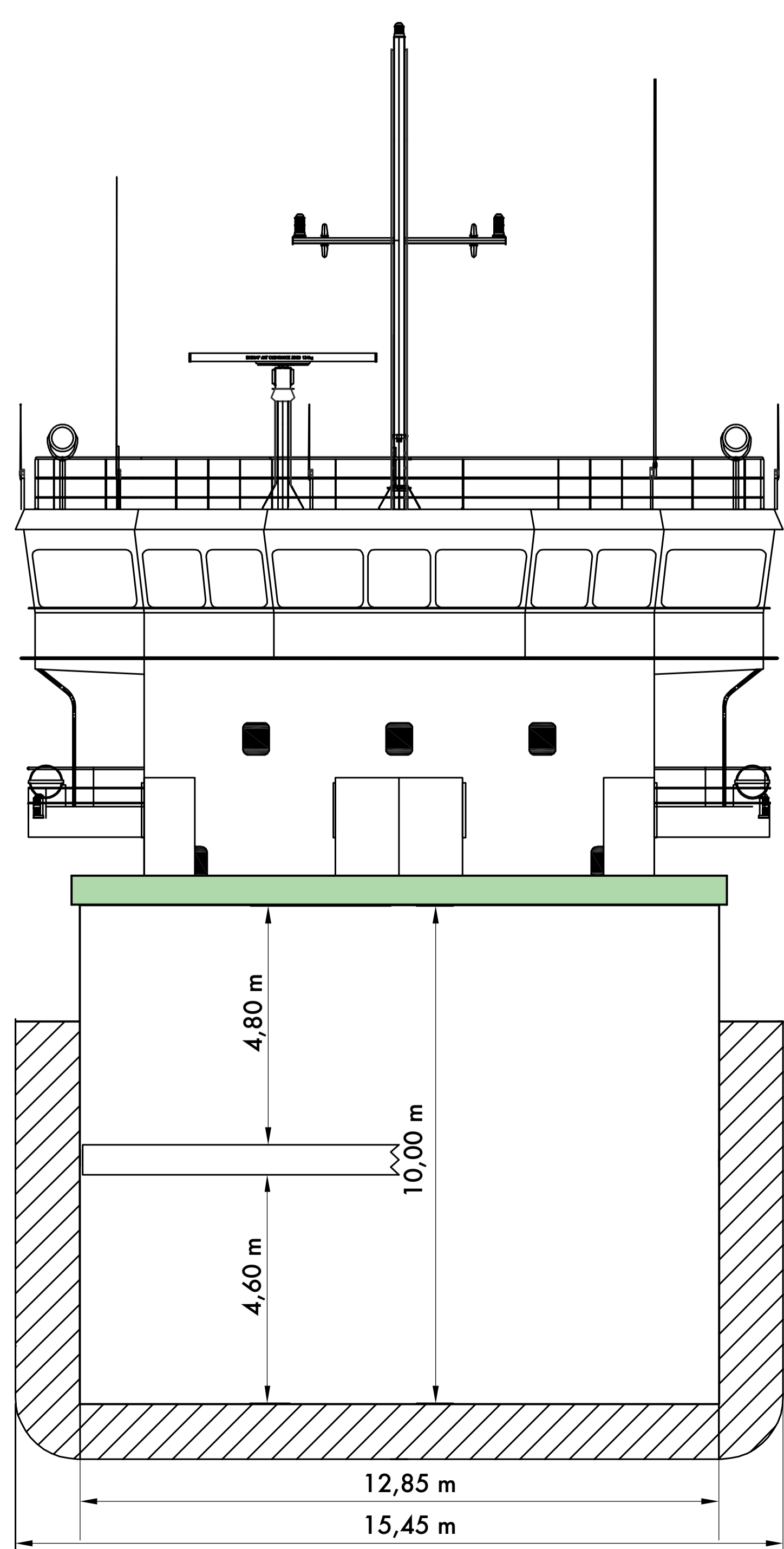

AFT

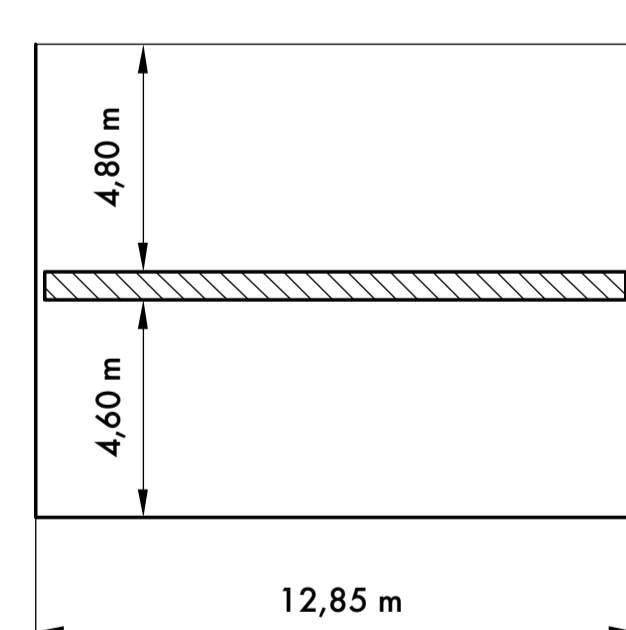

FORE

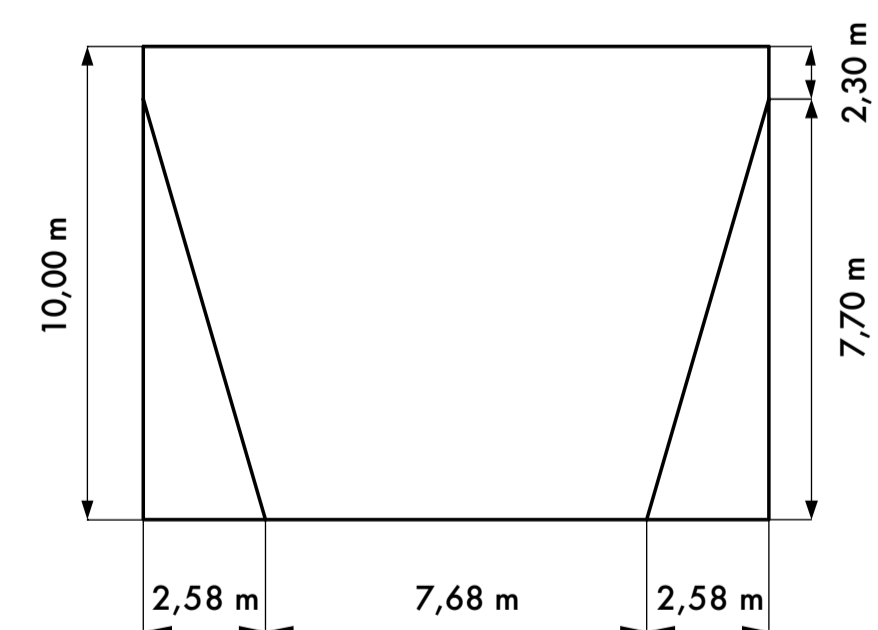

AFT VIEW

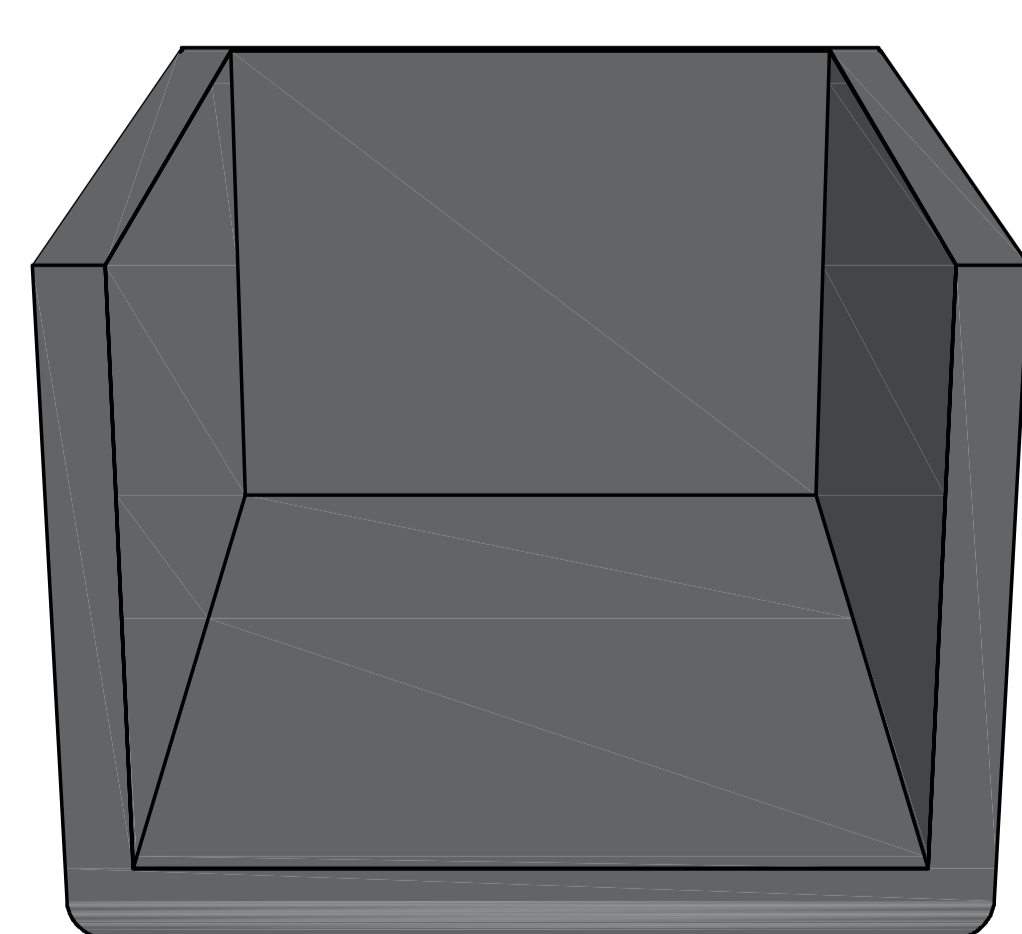

FORE VIEW

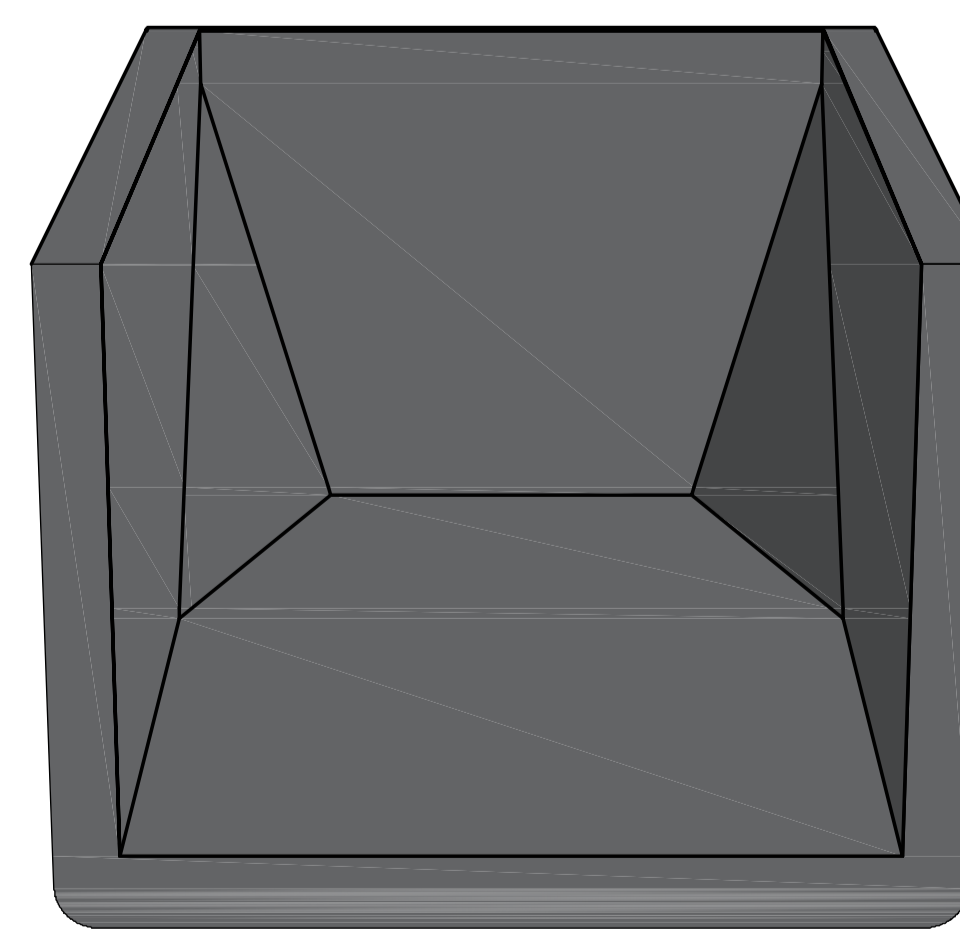

Capacity of holds

Position	A,B-10C	10C-D	10D-E	10C-E	E-8F	8-F-G	G-H	H-I	I-J	J-K	2K-1
Length (m)	1,47	0,99	4,35	5,94	4,35	4,35	10,51	10,65	7,76	2,11	7,68
Volume (m³)	188,8	127,5	559,2	763,6	559,2	559,2	1350,9	1368,7	998,1	271,17	987,6
Volume (cft)	6670	4506	4506	26966	19749	19479	47710	48338	35250	9576	34879